

# **A-GPRS1081**

## **User's Manual**



**Beijing ART Technology Development Co., Ltd**

# *Contents*

<i>CONTENTS</i> .....	2
<i>CHAPTER 1 INTRODUCTION</i> .....	3
1.1 Overview.....	3
1.2 Features .....	3
1.3 Check List .....	4
1.4 Installation Guide.....	4
<i>CHAPTER 2 HARDWARE INSTRUCTION</i> .....	5
2.1 Terminal Distribution.....	5
2.2 Analog Input.....	6
2.3 Analog Output.....	6
2.4 Digital Input .....	7
2.5 Digital Output .....	7
2.6 Serial Communication.....	8
2.7 DIP switch.....	8
2.8 Power Supply .....	9
2.9 Status lights .....	9
2.10 Potentiometer .....	9
<i>CHAPTER 3 PARAMETER CONFIGURATION</i> .....	10
Local COM port configuration mode.....	10
GPRS-Config.exe configuration program.....	10
2.1.1 GPRS-Config.exe Configuration Program.....	10
2.1.2 AT Parameter Configuration Protocol.....	11
2.3 Message Configuration .....	13
<i>CHAPTER 4 FUNCTION SETTINGS DESCRIPTION</i> .....	14
<i>CHAPTER 5 SERVER PROGRAM</i> .....	17
<i>CHAPTER 6 NOTES AND WARRANTY POLICY</i> .....	18
6.1 Notes .....	18
6.2 Warranty Policy.....	18

## ***Chapter 1 Introduction***

### **1.1 Overview**

A-GPRS1081 is wireless data transmission terminal device which based on GPRS, supplies AI, AO, DI, DO, it can realize long-distance communication, wireless communication and Network communication.

#### **Operating System Support**

The operational under most popular operating systems such as windowsxp/2000/2003/Vista etc. however, ART device drivers provide easier installation, configuration and better performance for windowsXP, windows2000/2003, Vista, Please refer to the respective operating system's manual for how to install and configure the standard driver.

#### **Wide applications**

A-GPRS1081 module has a wide range of applications, following are some typical applications:

- 1 Power Down Automatically Meter System
- 2 Environment Monitoring Systems
- 3 Urban Street Lamps Lighting System
- 4 Industrial Automation Control Systems
- 5 Financial Control Systems
- 6 Mine Control System
- 7 Oil Control Systems

### **1.2 Features**

- ◆ 8-channel 16-bit differential isolated analog input ( $\pm 10V$ )
- ◆ 2-channel 12-bit isolated analog output (0~5V/0~10V)
- ◆ 8-channel isolated digital input
- ◆ 8-channel relay output(30V<sub>DC</sub>@2A)
- ◆ Support data centers
- ◆ Support data center dynamic domain name or IP address access
- ◆ Support three working mode: on-line forever, idle offline, and idle power-off
- ◆ Support the automatic re-connection function
- ◆ Support local and remote graphical interface for configuration and the maintenance
- ◆ With power source, connection status, and the operation indicator light;
- ◆ Support local and remote firmware upgrade
- ◆ Supply RS-232/485 COM port
- ◆ Reliable design of multiple hardware and software, and build-in the watchdog

- ◆ Supply single voltage from +7V ~ +26V (Recommended +9V ~ +12V)
- ◆ Operating Temperature: -20°C ~ +70°C
- ◆ Operate humidity: 90%;

A-GPRS1081's diagram is as follow:



## 1.3 Check List

Unpack the A-GPRS1081 series package, you should find the following items:

- 1 A-GPRS1081 data transmission module;
- 2 Device driver diskettes:
  - a) Driver;
  - b) User's manual (this manual).
- 3 One serial port cable.
- 4 One Power Supply.

## 1.4 Installation Guide

Methods about how to install A-GPRS1081 in different operating systems are the same, our company provides a CD-ROM that contains the installation program "Setup.exe", and users double-click the installation program, then through the prompting of the interface to complete the installation.

## Chapter 2 Hardware Instruction

### 2.1 Terminal Distribution

Terminal Distribution picture is shown as following (figure 2.1):

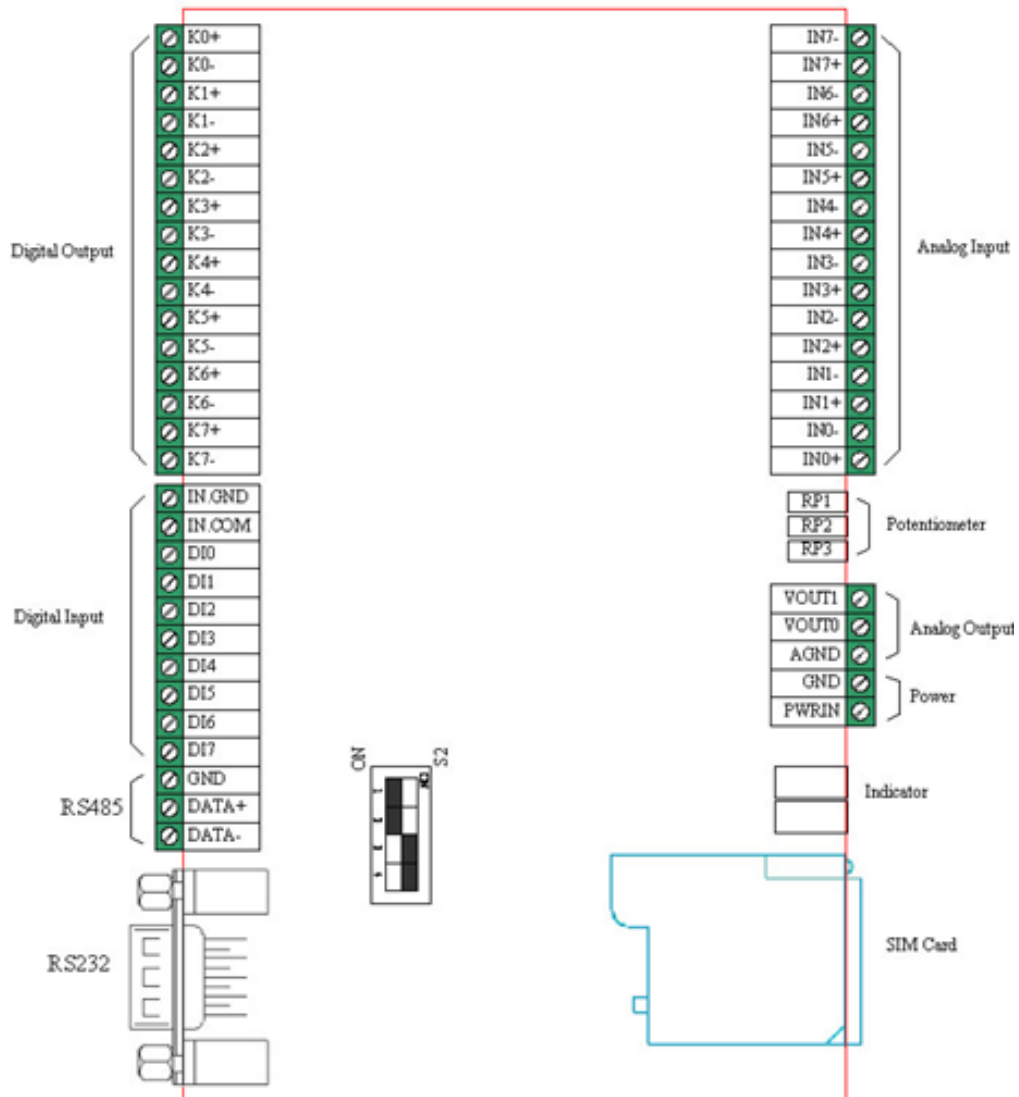

Figure 2.1

## 2.2 Analog Input

A-GPRS1081 is differential isolated analog input, input range:  $\pm 10V$ .

The specific connection method in Figure2.2:

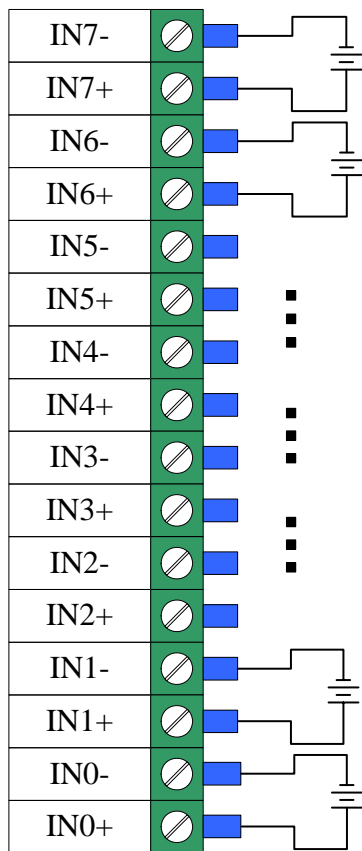

Figure2.2

**Note:** first, we should give the power to A-GPRS1081, and then give analog input signal in order to ensure the effective collection.

## 2.3 Analog Output

A-GPRS1081 has 2-channel 12-bit analog output.

Connection method in Figure 2.3

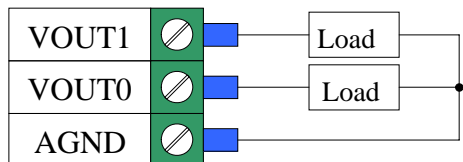

Figure 2.3

## 2.4 Digital Input

A-GPRS1081 has 8-channel isolated digital input, Connection method in Figures.

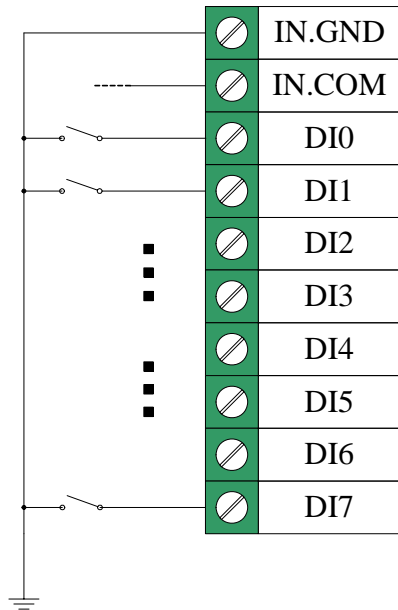

Figure 2.4-1 dry input connection

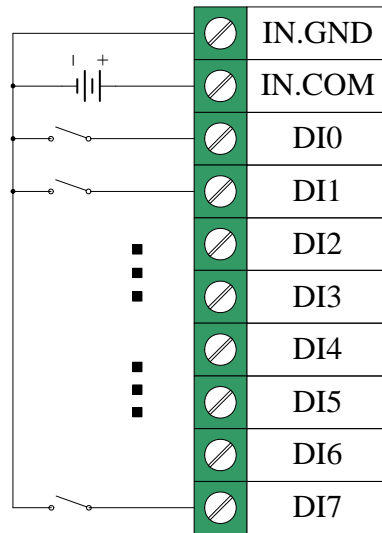

Figure 2.4-2 wet input connection.

## 2.5 Digital Output

A-GPRS1081 digital output is relay mode. Connection method is shown in Figure 2.5.

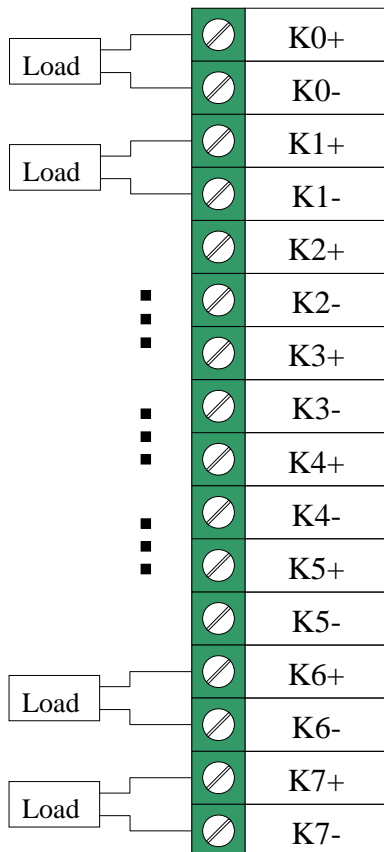

Figure 2.5

## 2.6 Serial Communication

A-GPRS1081 supplies one DB9 male connector, which is 5-wire serial.

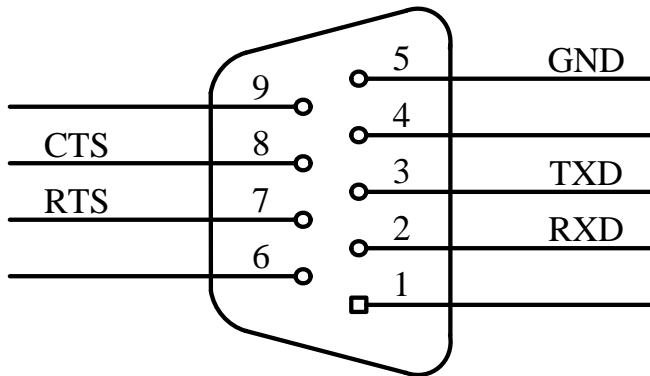

Figure 2.6

A-GPRS1081 also supplies RS485 communication interface.

## 2.7 DIP switch

DIP switch S2 on the A-GPRS1081, is used to switch serial connections. When DIP switch is allocated to "ON", it stands for "1", allocated to another side stands for "0."

When you select RS485 mode, the 1 and 2 DIP switches are allocated to "ON", the 3 and 4 are allocated to the other side, schematic as follows:

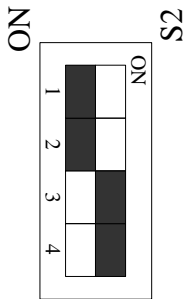

When select RS232 mode, the 3 and 4 DIP switches are allocated to "ON", the 1 and 2 are allocated to the other side, schematic as follows:

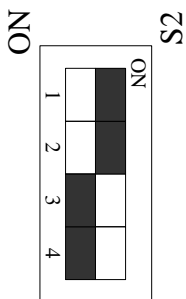



## 2.8 Power Supply

Power supply connection method shown in Figure 2.7, PWRIN connects with GND in order to supply power.

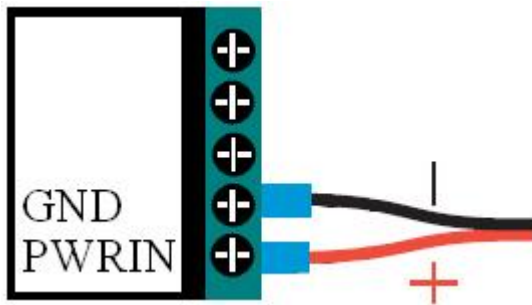

Figure 2.7

## 2.9 Status lights

A-GPRS1081 is equipped with four LED indicator lights: PWR (Power LED), DATA (communications lamp), NET (network status lights) and GPRS (GPRS status lights).

PWR: Power indicator light, on for normal.

DATA: communications indicator.

NET: Network Status lights, blinking stands for network status.

GPRS: GPRS status lights, after electricity, if it lighting all the time, it stands for GPRS network existence.

The indicator as follows:

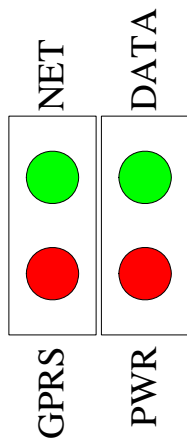

## 2.10 Potentiometer

A-GPRS1081 has five regulatory potentiometers (RP1, RP2, RP3, RP4 and RP5), Their regulatory functions are as follows:

RP1: DA analog output full-scale adjustment

RP2: VOUT1 analog output zero adjustment

RP3: VOUT0 analog output zero adjustment

RP4: VOUT1 analog output full-scale adjustment

RP5: VOUT0 analog output full-scale adjustment

# Chapter 3 Parameter Configuration

We have three ways to configure parameters of A-GPRS1081: these are local COM port configuration, long-distance configuration and message configuration.

## Local COM port configuration mode

Local COM port configuration uses A-GPRS\_Config.exe or AT command.



Figure 3.1.1 Schematic diagram of the local serial port configuration

There are two ways can enter to the local configuration mode, show as follows.

**When DTU power-on:** when give the power to DTU, it will check whether there is space in the serial port, if there is space, that the user requested access to the configuration mode. Therefore, we only need to send space to serial port continuously before give the power to DTU (baud rate 115200, 8-bit data bit, 1 stop bit, noparity), and then give the power to DTU, you can enter the local serial port configuration mode.

**Note:** If it receives character “e” when give the power to DTU, it will rest DTU; if it receives character “a”, we can do AT mandate for SIM300.

**2 When DTU normal working:** when DTU is in a normal communication status, we can send characters in table 2.1 to DTU through serial port to make DTU exit present work mode, and then enter the configuration mode.

Table2.1

Pre-idle time	Character	Idle interval time
Least 100ms	+++ is set \r\n	Least 100ms

## GPRS-Config.exe configuration program

### 2.1.1 GPRS-Config.exe Configuration Program

The method of A-GPRS1081 enters to the configuration mode: (first do not give the power to module)

- 1 Connect the COM port with the module.
- 2 Click the “enter configuration status” button, and then give power to A-GPRS1081 quickly. (Show as the following)

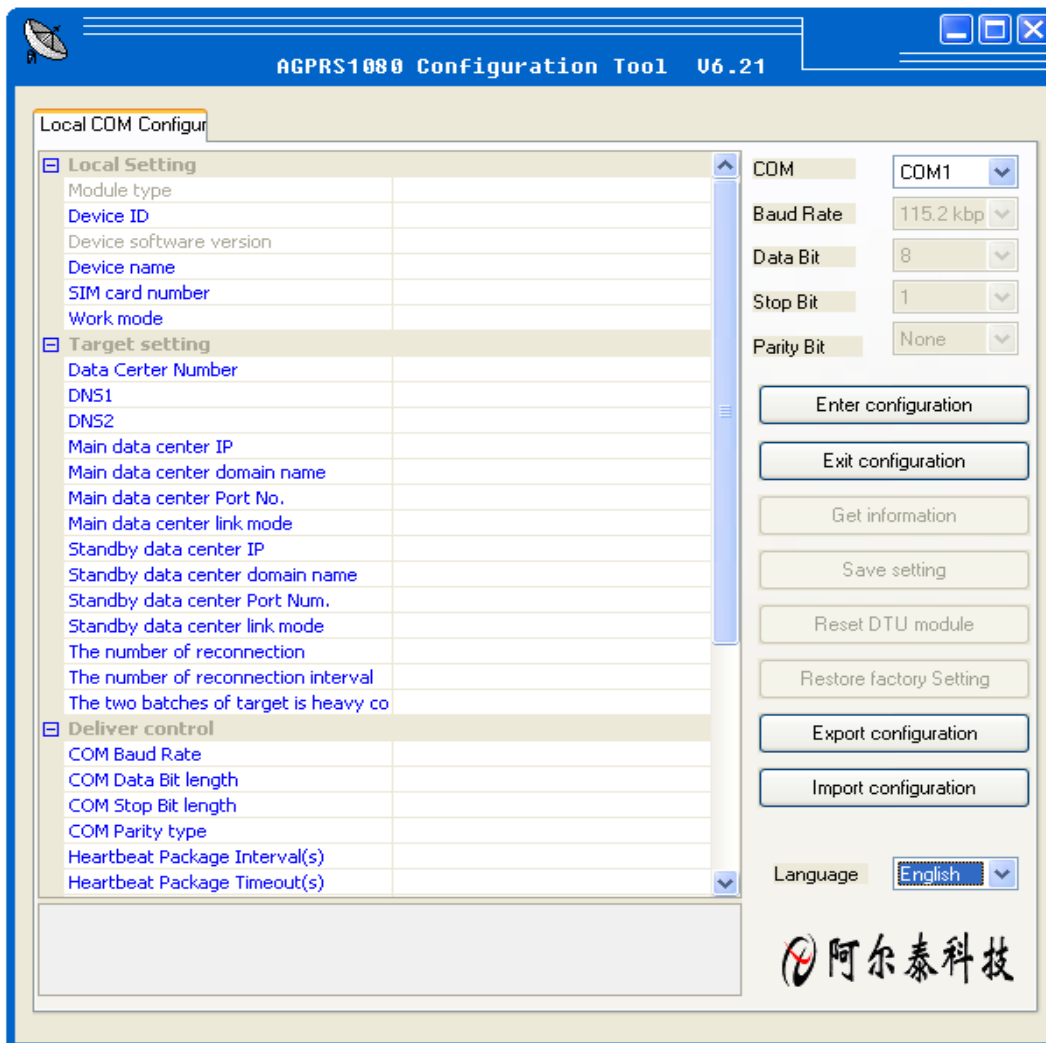

- 3 Click the “get information” button, then we can read the information of module, or we can wait for seconds because it can get information automatically.
- 4 In the left of user interface, there is a “local COM port configuration” tool, we can change the information in it, when it has been changed, we can save new information by clicking the “save configuration” button.

### 2.1.2 AT Parameter Configuration Protocol

After DTU into the configuration mode, accordingly we can send command frames with configuration message, by command frames we can read or write parameters. Command frames all use ASCII characters. This not only gives the user convenient to use hyper terminal for parameter configuration in absence of configuration tool, but also allows users to write the DTU configuration program in their own device easily. Command frame structures are shown in Table Table2.2. There are two types of command, write commands and read commands. Write commands are used to configuration parameters, read commands are used to query the current configuration. The difference between them is that read commands are not with configuration parameters and characters after the command are different. Write commands "=" said the assignment. Read command "?" said the question.

Command codes are different because the configuration objects are different, but these codes must comply with requirements of regulations (show as Table 2.3). If use other command codes, DTU will return “ERR CMD”, for another way, if write command with parameter configuration is not illegality (for example the baud rate has surpassed the scope of requirement), then DTU will refuse to receive this parameter and return “ERR DATA”.

**Note:**

1 The data in command frame is all ASCII characters, and all inputted characters do not be divided the big or small letter;

2 Command codes can be found in Table 2.3

3 Writing command frames' length can be found in Table2.3

Table 2.2

Command Frame Type		Format
Writing Command		AT+ command code=parameter
Writing Response	Right	OK\r\n
	Command mistake	ERR CMD\r\n
	Parameter mistake	ERR DATA\r\n
Reading command		AT+ Command Code?\r\n
Reading Response		Command code =Parameter\r\n

Table2.3

Function name		type	code	Maximum length	Settings
Local Setting	Module type	R	DTUTYPE	10	Such as ART1081
	Device ID	R	DTUID	15	unique ID,can not change
	Device software version	R	SWVER	5	Such as V1.00
	Device name	RW	DTUNAM	15	Such as ARTDTU01
	SIM card number	RW	PHON	11	Such as 15810437433
	Work Mode	RW	MODE	1	0:onlineforever1:idle winding2:idlepower-down
Target Setting	Data Center Number	RW	SVRCNT	1	1~2
	DNS1	RW	DNS1IP	15	Such as 202.106.0.20
	DNS2	RW	DNS2IP	15	Such as 211.136.17.107
	Main data center IP	RW	SVRIP	15	Such as221.218.157.55
	Main data center domain name	RW	SVRNAM	40	Such as'www.sohu.com'
	Main data center port No.	RW	SVRPORT	5	Such as 80
	Main data center link mode	RW	SVRMODE	1	0: TCP connection

					1: UDP connection
	Standby data center IP	RW	SVR1IP	15	Such as 192.168.0.1
	Standby data center domain name	RW	SVR1NAM	40	Such as "www.163.com"
	Standby data center port No.	RW	SVR1PORT	5	Such as 80
	Standby data center link mode	RW	SVR1MODE	1	0: TCP connection 1: UDP connection
	The number of reconnection	RW	TRYCNT	2	1~99
	The number of reconnection interval	RW	TRYTIM	5	10~65534s
Transfer Control	COM Baud Rate	RW	SERBAUD	6	300~115200
	COM Data Bit length	RW	SERDAT	1	5~8
	COM Stop Bit length	RW	SERSTP	1	1~2
	COM Parity type	RW	SERCHK	4	
	Heartbeat Packet Interval(s)	RW	BEATTIM	5	30~65534s
	Heartbeat Packet Timeout(s)	RW	BEATOUT	5	30~65534s
	Idle linetime	RW	IDLETIM	5	30~65534ms
	Whether local port access	RW	ISLOCAL	1	0:GPRS 1:local port
	Local device ID	RW	MTU	4	1~1024 byte
Network Parameters	APN	RW	APN	20	Default empty
	APN User name	RW	USRNAM	20	Default empty
	APN password	RW	PWD	20	Default empty
	SMS Center Number	RW	SMSNO	14	Default empty
	SMS Certification User 1	RW	USERNO1	14	
	SMS Certification User 2	RW	USERNO2	14	
	SMS Certification User 3	RW	USERNO3	14	
	Module Password	RW	DTUPWD	6	ON:putout
Control Command	Debugging information output	RW	DBGINF	3	ON:putout

## 2.3 Message Configuration

SMS configuration is a mobile phone, enter commands to configure, but please note:

---

### Note:

**One message only can send one command, format is: 6 passwords + ":" + command (without the prefix "AT +"). All characters are Western. Not only the telephone number is the same as certification number, but also the passwords have been passed, then SMS configuration can work. SMS wake-up command "WAKEUP".**

**SMS Configuration Support Telephone wake-up: telephone call's time must over two rings , and was hung up after the wake-up.**

---

## ***Chapter 4 Function Settings Description***

### **Export Configuration**

Save the modified configuration items.

### **Import Configuration**

Load the configuration items previously saved.

### **Reset DTU Module**

Software reset actions will be executed.

### **Restore Factory Settings**

Restore module to factory settings in case of configuration confusion.

### **SWVER**

Software version.

### **DTUNAM**

DTU device name, be used to distinguished different devices when multiple modules are being used. DTUNAM limited to 15 characters.

### **SIM Card Number (PHON)**

Mobile phone number, 11 ASCII characters, such as "15810437433".

### **MODE**

There are three modes for A-GPRS1081: "Always online", "idle offline", "idle power down".

- Always online: It will connect to the preconfigured server when power on the module. And it will be kept online all the time so the data can be transmitted at any time.
- idle offline: It will connect to the preconfigured server when power on the module. The module will disconnect and turns to the sleeping mode if there isn't any data in a period of time. There are three methods to enable re-establish connection between the module and the server.
  - Send data to the serial port of the module, the module will connect to the server and then send the out. .
  - Telephone wake-up: call the SIM card number, hang up after it rings for two times, the module will re-establish a connection with the server
  - SMS wake-up: set one of the SMS certification users to the SIM card number in the Configuration Tool. The format of the number is "+861\*\*\*\*\*". (for China's SIM card, it is 86) Send the SMS "888888: Wakeup". It will return "OK" which means the module has re-connected to the serve.
- idle power down: after the module disconnecting the connection with the server, the module will cut off the power of GPRS module, and make the system into power-down status to achieve low power consumption

There is only one method to wake up the module: send data to the serial port of the module, the module will connect to the server after the data is sent successfully.

## DTUMODE

This parameter is used to set the module's functionality mode, "CLIENT" or "SERVER". For "CLIENT" mode, the module connects the data center server as a client. For "SERVER" mode, the module waits for the connection from the client as a server. When use the point to point function, configure one module "CLIENT", and the other "SERVER".

## SVRIP, SVRNAM, SVRPORT, CNTMODE (the parameters of the main center server)

A target server configuration includes IP address and port number, if the server does not have a fixed IP address, you can use the domain name. When the server IP address is validity, the domain name will be ignored. In communication network, it has TCP and UDP communication.

## SVR1IP1, SVR1NAM1, SVR1PORT1, CNTMODE1 (the parameters of the secondary center server)

A target server configuration includes IP address and port number, if the server does not have a fixed IP address, you can use the domain name. When the server's IP address validity, the domain name will be ignored. In the several attempts to connect the main central server fails, the module will automatically switch to connect alternate central server. When using the standby server, if it suddenly disconnected during the remote configuration, the module will re-connect standby server. If it suddenly disconnected in operating mode, the target server will switch back to the main central server.

## TRYCNT, TRYTIM, TRYSPAC

The number of target re-connection, used to control the number of the same goal connection of the connection with batch. "0" stands for regardless of batch. The interval of target connection is used to control the time between two connections, the smallest time is 10s, and the longest time is 65.5536s. The interruption interval of target connection is used to control the time of two groups' connections, the smallest is 1 minute, and the longest is 65,534 minutes.

## SERBAUD

Serial baud-rates.

Table4.1 Supported baud-rates

Standard baud-rate									
300	600	1200	2400	4800	9600	19200	38400	57600	115200

## SERDAT, SERSTP

Serial data bit (stop bit) length.

## SERCHK

Check type of serial.

Table4.2 relationship between values and checking types

Baud-rate	No checking	Odd checking	Even checking	Compulsory to 1	Compulsory to 0
Set value	NON	ODD	EVEN	1	0

## BEATTIM

Users can set heartbeat packet interval time, the range is 30 ~ 65534 (unit: seconds).

## BEATDATA

User can manually set the heartbeat data, such as: "0x3F", using the AT command configuration, format: "AT + BEATDAT = 3F".

**SERS, MTU**

Frame interval of time and the maximum length of data packets

**IDLETIM**

Idle time of downline.

**APN, USRNAM, PWD**

APN name, user name, and password.

**LCOPORT**

Local port number.

**DTUPWD**

Login Password.

**DBGINF**

This parameter controls whether the data input is "echo" and whether there are "debug information" outputs.



## Chapter 5 Server program

Application framework

Show as figure:

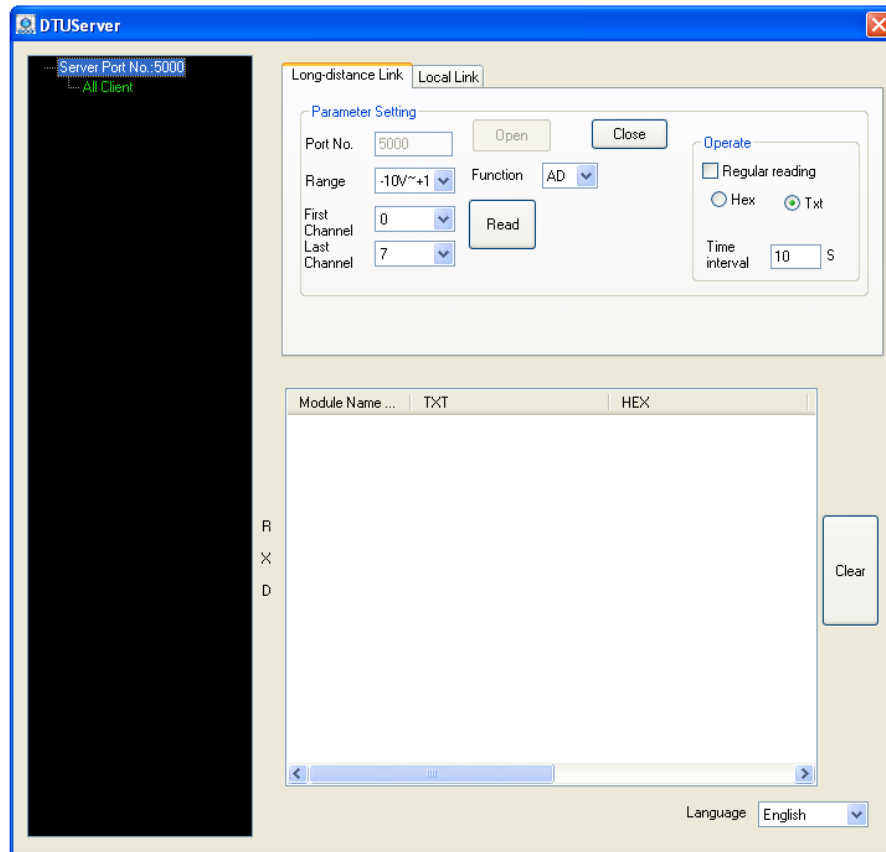

Note:

Default listening port is 5000; the server program only has one monitor port, allow 1000 clients to establish connection at the same time.

It can read the AD, DI, DO, DA manually, but also can be read through the timer.

Workflow:

1 Input port number in the port number edit box, click "Start"  .

2 If there is client connection, then you can visit the module.

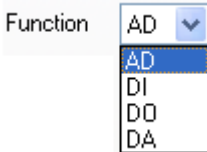
3 We can select different functions through "Function box"  .

4 It can read timing module data

 .

## ***Chapter 6 Notes and Warranty Policy***

### **6.1 Notes**

In our products' packing, user can find a user manual, a A-GPRS1081 module and a quality guarantee card. Users must keep quality guarantee card carefully, if the products have some problems and need repairing, please send products together with quality guarantee card to ART, we will provide good after-sale service and solve the problem as quickly as we can.

When using A-GPRS1081, in order to prevent the IC (chip) from electrostatic harm, please do not touch IC (chip) in the front panel of A-GPRS1081 module.

### **6.2 Warranty Policy**

Thank you for choosing ART. To understand your rights and enjoy all the after-sales services we offer, please read the following carefully.

1. Before using ART's products please read the user manual and follow the instructions exactly. When sending in damaged products for repair, please attach an RMA application form which can be downloaded from: [www.art-control.com](http://www.art-control.com).
2. All ART products come with a limited two-year warranty:
  - The warranty period starts on the day the product is shipped from ART's factory
  - For products containing storage devices (hard drives, flash cards, etc.), please back up your data before sending them for repair. ART is not responsible for any loss of data.
  - Please ensure the use of properly licensed software with our systems. ART does not condone the use of pirated software and will not service systems using such software. ART will not be held legally responsible for products shipped with unlicensed software installed by the user.
3. Our repair service is not covered by ART's guarantee in the following situations:
  - Damage caused by not following instructions in the User's Manual.
  - Damage caused by carelessness on the user's part during product transportation.
  - Damage caused by unsuitable storage environments (i.e. high temperatures, high humidity, or volatile chemicals).
  - Damage from improper repair by unauthorized ART technicians.
  - Products with altered and/or damaged serial numbers are not entitled to our service.
4. Customers are responsible for shipping costs to transport damaged products to our company or sales office.
5. To ensure the speed and quality of product repair, please download an RMA application form from our company website.